

BULLETIN

**Feb 2015
#0007**

**Detachable plug portion with connection device
(Plug adaptor device)**

This information bulletin is to give guidance on what may be required for detachable plug portion devices. There are essentially three versions of these devices as classified below:

Type A

A device that has AS/NZS 3112 flat pin plug pins and an outlet configured for connection to an appliance inlet within scope of AS/NZS 60320 for use with equipment in a direct plug in equipment configuration.

Type A device example:



Type B

A device that has AS/NZS 3112 flat pin plug pins and an outlet that is not for connection to an appliance inlet within scope of AS/NZS 60320 for use with equipment in a direct plug in equipment configuration.

Type B device example:



Type C

A device that has AS/NZS 3112 flat pin plug pins and an outlet that is configured for connection to an appliance inlet or interconnection coupler (plug connector) within scope of AS/NZS 60320 for use with an adaptor connected to a flexible cord (plug connector) so as to replicate a supply plug and flexible cord configuration.

Type C device example:

Note: the adaptor part fits within scope of AS/NZS 60320.2.2 as a plug connector

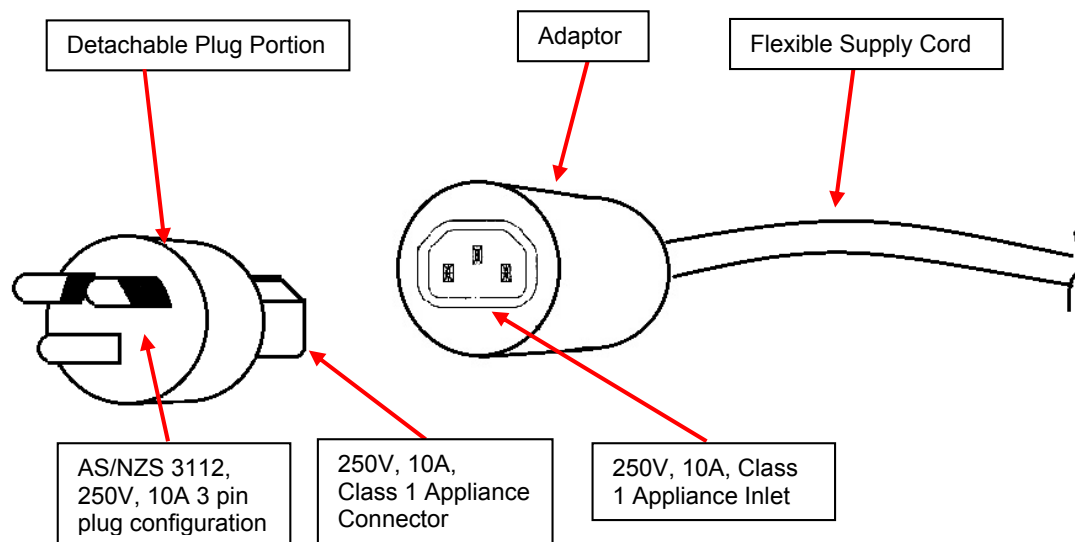

Type A or Type B devices do not fit within definitions that make them declared/prescribed/level 3 equipment in electrical safety legislation in Australia and New Zealand.

However they require assessment to ensure safety in such matters (but not limited to) there is adequate contact between the connection of the detachable plug portion and the equipment it is attached to, that such connections will remain resilient and effective over time, that no fire or electric shock hazard exists, that no access to live parts is possible when the detachable plug portion is detached, that the detachable plug portion will not become partly detached and create a fire hazard

Type C devices, detachable plug portion with their associated adaptor, are classified as a "Plug" under the definition of AS/NZS 4417.2 and must comply with AS/NZS 3112.

TESTING

Type A and Type B devices are tested as a component part of other equipment and would require:

- For Type A devices - compliance to requirements of AS/NZS 3105:2014 (output connector part complying with AS/NZS 60320.1 as a 10A 250V coupler) ,
Note: these Type A devices fit within scope of AS/NZS 3105.
- For Type A devices that is not a three pin plug configuration with its associated output connector of Class I classification shall not be able to be inserted into any standard sheet class I appliance inlet complying to AS/NZS 60320.1
- For Type A and Type B devices - Appendix J of AS/NZS 3112

For Type C devices, the detachable plug portion and adaptor are a plug and must be assessed as a combined unit fully to AS/NZS 3112 (with the outlet of the detachable plug portion assessed to AS/NZS 60320.1 and the adaptor portion assessed to AS/NZS 60320.2.2).

In addition to the above, the devices would require further assessment as listed below:

- For Type A devices where the outlet of the detachable plug portion is parallel to the supply pins, and for all Type B and C devices, disengagement of the detachable plug portion from the equipment (or adaptor in Type C) must require at least two simultaneous independent actions or the use of a tool (Type A devices where the outlet of the detachable plug portion is not parallel to the supply pins – as per the Type A device example picture above – do not need to comply with this requirement).
- For all Types – AS/NZS 3112 “Attachment of covers” test for plugs
For this test the detachable plug portion is considered the plug and the equipment (or adaptor in Type C) it plugs into is considered the cover and compliance is obtained by the detachable plug portion not becoming detached from the equipment/adaptor
Note: this test is to ensure the detachable plug portion is not of such design that it may accidentally fully or partially detach causing a poor electrical connection. The test of AS/NZS 3112 “temperature rise test” for plugs is conducted immediately after this test without disturbing the sample.
- For all Types – AS/NZS 3112 “Temperature rise test” for plugs
- For Type A and Type B devices – tests to the requirements of the other equipment relevant standard not covered by the above requirements or superseded by the other equipment relevant standard (i.e. tested as part of the equipment the device is used with and the requirements in that standard adequately address the above requirements).
- For Type C devices the adaptor part must be a non-rewireable component and comply with all the test criteria of AS/NZS 3112 “Tests on non-rewireable plugs and flexible cords”
- For Type C devices the detachable plug portion shall not allow interconnection between Class II detachable plug portion and Class I adaptor configurations.

Additional requirement for Type B devices

Testing for Type B devices would include evidence to show compliance to AS/NZS 3112:2011 Appendix J for the plug portion and evidence of the following for the outlet connection:

- There shall be no access to live parts of the outlet when test probe 13 of IEC 61032 is applied in all directions
- The contact between the current carrying connection parts be self-adjusting so as to provide adequate contact pressure.
- The means of retaining connection not relying on the resiliency of insulating material and the contacts shall have sufficient resiliency to compensate for any shrinkage or deformation and to retain adequate contact pressure in service.

Guidance on sufficient resiliency would include:

- There is metal to metal compression fit of the live parts, and
- The withdrawal force of each metal compression fit connections complies with withdrawal force requirements of single pin withdrawal force of AS/NZS 60320, and
- The temperature rise of the connection does not exceed temperature rise limits for terminals as per the relevant equipment standard of the equipment the device is used with (or 45k rise if no limit is stated in the relevant standard).

or

- There is a spring tension on the metal parts of the connection that applies a pressure of 2N on the connection and for the part that has the spring tension there is a travel of at least 2mm; and
- The temperature rise of the connection does not exceed temperature rise limits for terminals as per the relevant equipment standard of the equipment the device is used with (or 45k rise if no limit is stated in the relevant standard), and
- The plastic materials (on both the plug portion and equipment portion) around the contact passes a ball pressure test. The test is conducted at the highest temperature determined from:
 - o $40\text{ }^{\circ}\text{C} \pm 2\text{ }^{\circ}\text{C}$ plus the maximum temperature rise determined during normal operation tests; or
 - o $125\text{ }^{\circ}\text{C} \pm 2\text{ }^{\circ}\text{C}$; or
 - o $25\text{ }^{\circ}\text{C} \pm 2\text{ }^{\circ}\text{C}$ plus the maximum temperature rise determined during abnormal operation tests.

CERTIFICATION

Type A or Type B devices are considered as a component part of other equipment and do not require separate certification (if the other equipment requires certification then the Type A or Type B device is tested with the equipment, taking into account the testing requirements of this document).

Type C devices are considered a Plug (detachable plug portion and adaptor together) and require certification (such certification being conditional and related to the adaptor it is assessed with)

If certification is requested the following applies:

Type A devices fall within the scope of AS/NZS 3105:2014 so can be separately certified as a component part to that standard, however they still require to be tested to all the requirements above and certificate must have conditions as required below.

Type B devices do not have a separate standard that applies to them, they may be separately certified as a component part to AS/NZS 3112:2011 Appendix J - if there is evidence the requirements for the device and its outlet have been covered by the other equipment standard (i.e. the device has been tested as part of the equipment the device is used with) and certificate must have conditions as required below.

Type C devices are certified to AS/NZS 3112:2011 as a combination of the detachable plug portion and the adaptor part connected to the flexible cord (it is permissible to have reference to AS/NZS 60320.1 for the outlet of the detachable plug portion and AS/NZS 60320.2.2 for the adaptor)

Conditions

If a Type A or Type B device part is to be separately certified the certificate also shall have a condition of certification listed on the certificate.

The condition to include that the certification is only valid when the item is used with end product xxxx (where xxxx is a list of all brand/model numbers of end equipment the item has been tested with to show as a combination it complies with the end product relevant safety standard).

Note: This is to cover, for example but not limited to, such aspects as temperature limits of connections, suitability of connection method to the equipment, tumble barrel test, strain on socket –outlets.

The certificate for Type A or Type B device is to also indicate condition the device cannot be sold as a separate part (i.e. it is only sold with the equipment it is certified with). The device can be retained by supplier as a spare part for such equipment supplied only under warranty claims.

A Type C device certificate is to include conditions that the certificate is only valid when the item is used with the adaptor part that it has been assessed with, and also indicate condition the device cannot be sold as a separate part (i.e. it is only sold with the adaptor it is certified with). The device can be retained by supplier as a spare part for such equipment supplied only under warranty claims.

NOTE: the information herein is for guidance, it is understood the joint Australian and New Zealand standards committee responsible for plugs is reviewing requirements for such detachable plug devices to be included in the relevant standard and this information sheet will be reviewed once the work of that standards committee is completed.

References

AS/NZS 60320.1:2004 cl 13.5, 17
AS/NZS 60335.1:2011 cl 28.2
AS/NZS 3100:2009 cl 4.6.1
AS/NZS 60950.1:2011 cl 3.1.8
AS/NZS 60598.1:2013 cl 4.11.1
AS/NZS 3015:2014
AS/NZS 60695.10.2:2004
AS/NZS 3112:2011
AS/NZS 60320.2.2